

AUT164 - Housing for seniors  
10/01/2023

GROUP 8 - Emma Law-Bo-Kang, Linus Sjöström Fransson, Afsaneh Tayebi

# NEW BREATH IN THE VILLAGE

A DEMENTIA VILLAGE FOR UTBY



# Dementia village in Utby

## PROGRAM

The project site is located in Utby, Gothenburg, in a residential area of small villas. The program requires to design a dementia village of 80-100 apartments split into units with common areas. Moreover, good connections with outdoors is an important part of this kind of project. The particularity of such a program is that it is not only residential that must be designed, but also a whole organization for the staff to be able to work in good conditions. This project requires good housing qualities while being efficient and practical from a healthcare point of view. Another part of the program was to think of public functions that the neighbourhood could also benefit from.

## SITE

The site in Utby is quite enclosed since no road is directly reaching it. Moreover, it is a sloping terrain, around twenty meters height difference from one side to the other. It is currently used as a public wood with paths. Everyone can pass by and have a walk. All of the vegetation might be worth saving. On the eastern part of the site stands an allotment garden, which is also the flattest part of the terrain.

## SURROUNDINGS AND CONNECTIONS

The area is mainly residential with few stores. We can find a lot of pre-schools and schools with some playgrounds. Several sport facilities (indoor and outdoor) are located quite close and a big forest borders the north side. However, there are no cultural buildings in the area except churches.

To reach the site of the village, several bus stops are between 5-10 minutes away by walking and several small roads also surrounds the site.



Potential difficulties connecting to the existing road network

Nearby small scale single family housing

Close connections to nearby pre-schools

Relatively flat terrain used for allotment gardens

Vegetation that might be worth saving

Enclosed site

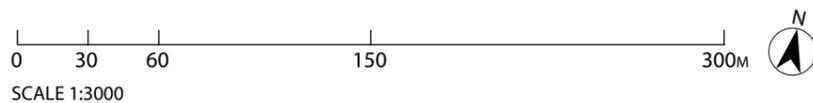

# Intentions

## APPROACH

The concepts of our project rely on three different aspects: the person, the site and the community. In the design, it translates into:

- 1/ a patient-centered approach
- 2/ a connection with nature and integration to the surroundings
- 3/ a strong sense of community with social aspects

## WORKING WITH SCALES

By thinking with different scales we aim to provide a real sense of village, to stay faithful to a common rhythm of life and to work on realistic and humanistic approach.

*\*Different scales in the environment:* from the private french balcony to the public wood by the way of the common garden.

*\*Different scales in social:* from the small group of residents living in one unit to people that are not part of the facility and from other generations: having a strong connection to the neighbourhood and schools around.

*\*Different scales in privacy:* from the very private apartment to the public building by the way of the common spaces in the units.

One of our big concerns was to find a way to break the scale down as we wanted our village to fit into the neighbourhood where there mostly are small villas. By using different colors, different types of roofs and materials, we are reproducing a village aspect while keeping one building which is all indoor connected to facilitate the staff's flow.

## GOALS

FIT INTO CONTEXT

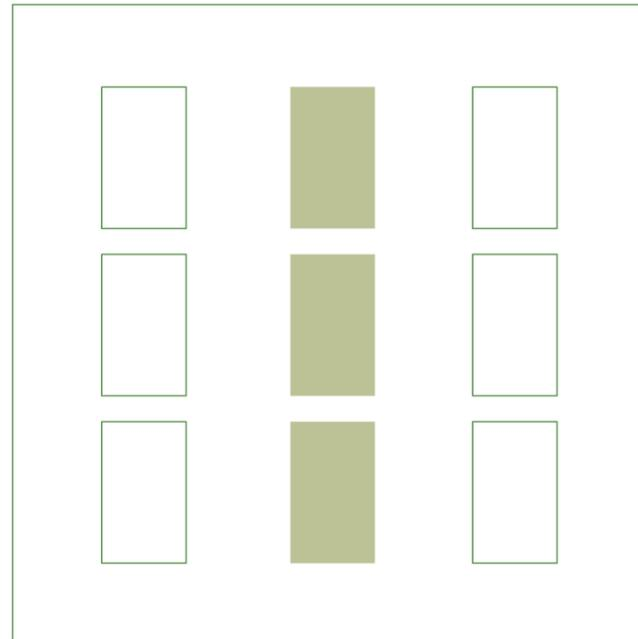

MOVEMENT & FLOW

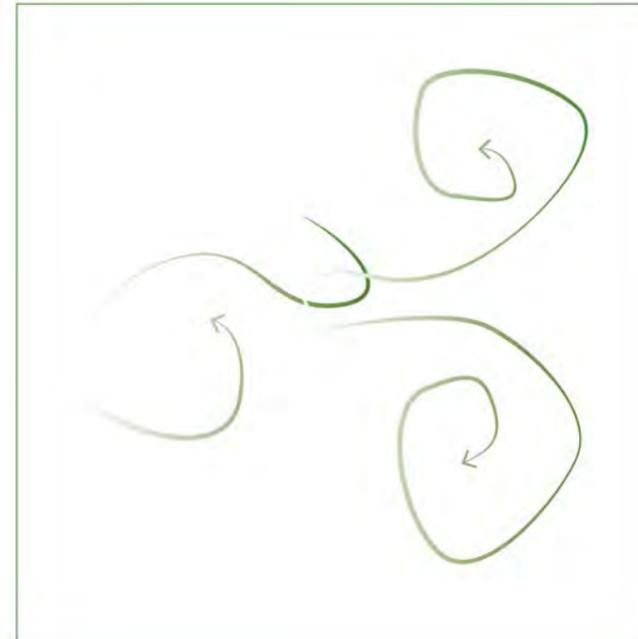

SENSE OF VILLAGE

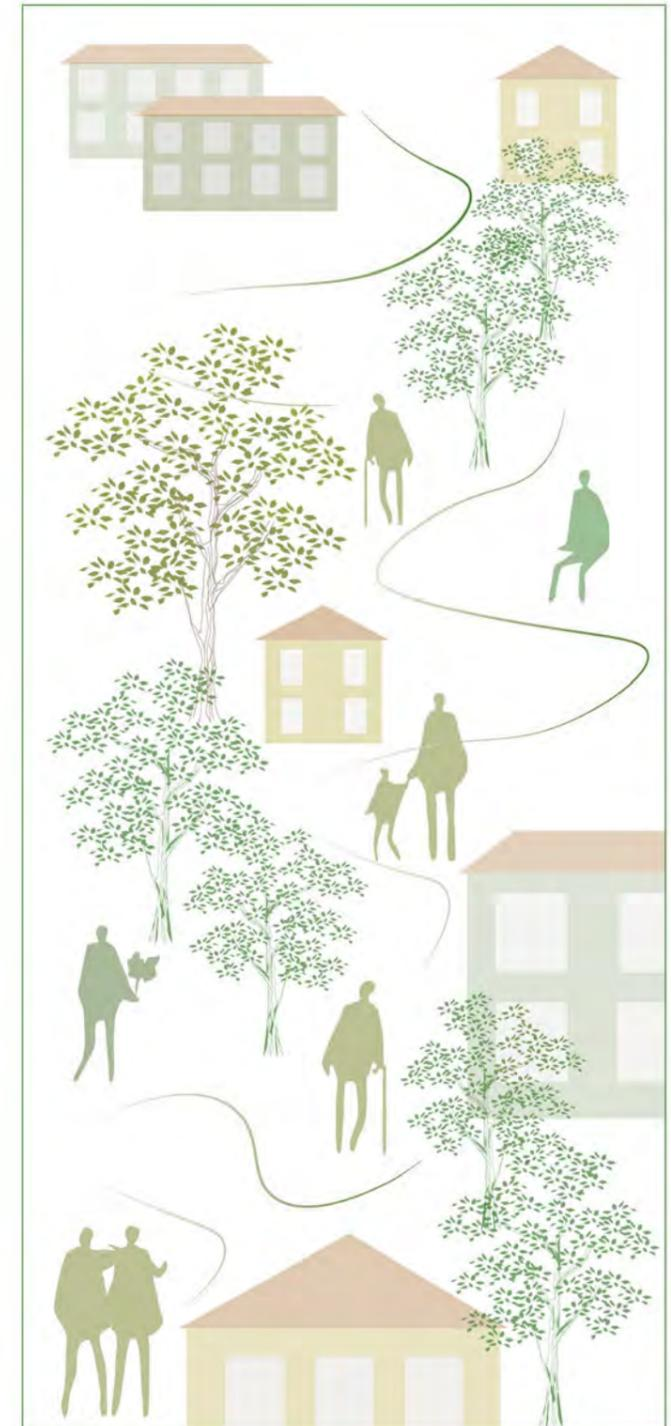

CONNECTION TO NATURE

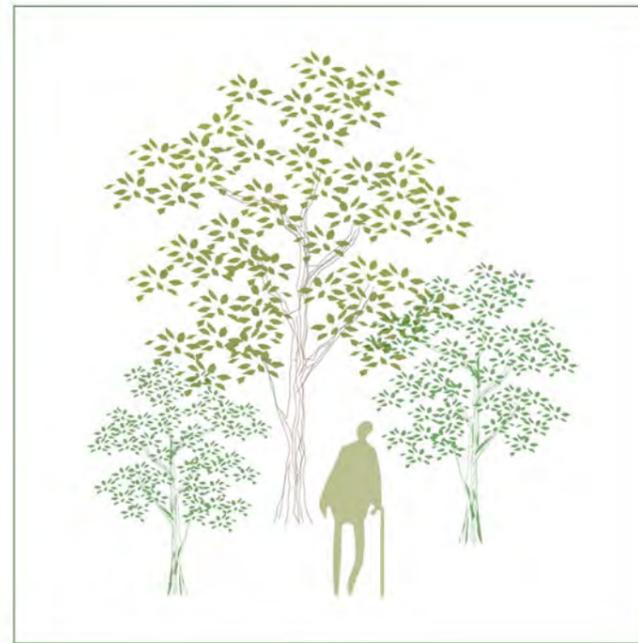

DIFFERENT SCALES (SOCIAL & PRIVACY)



# Site plan

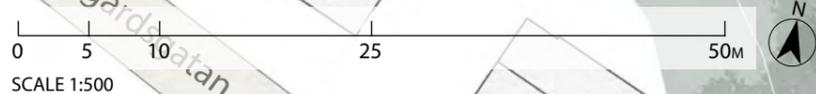

# Volume concept

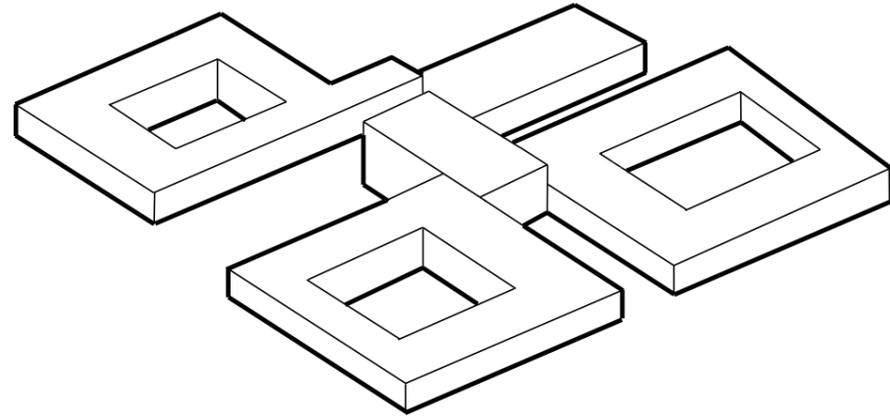

1. Volume

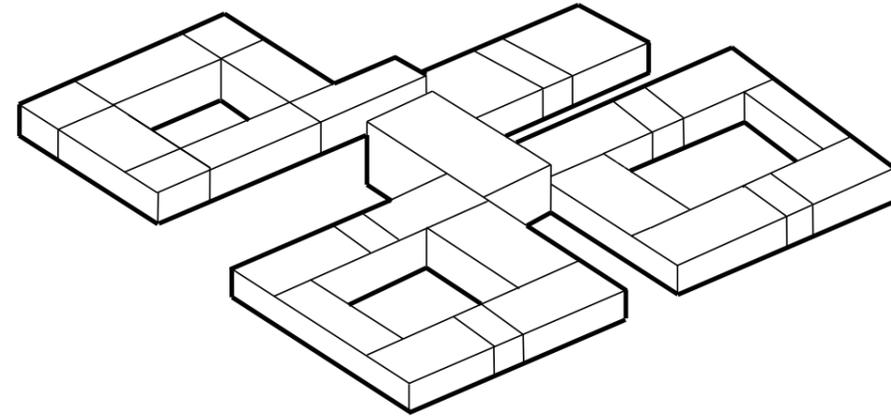

2. Scale down the volume

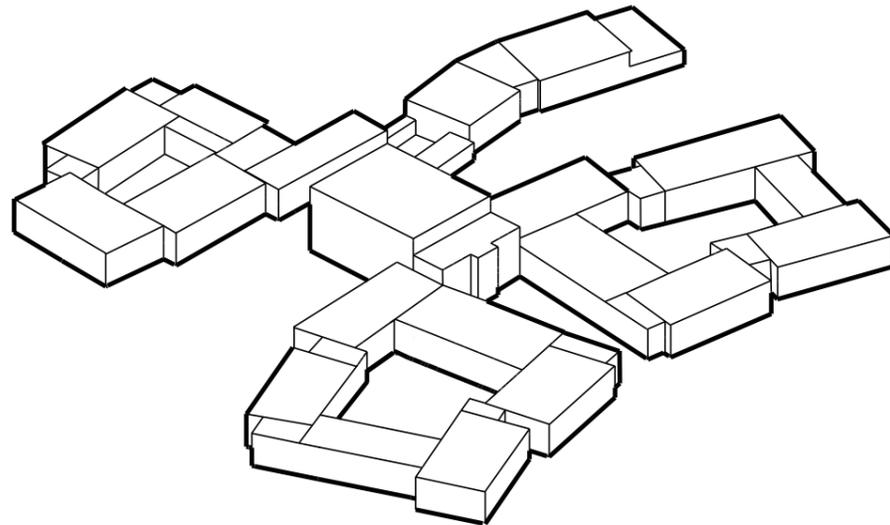

3. Adapting to the topography

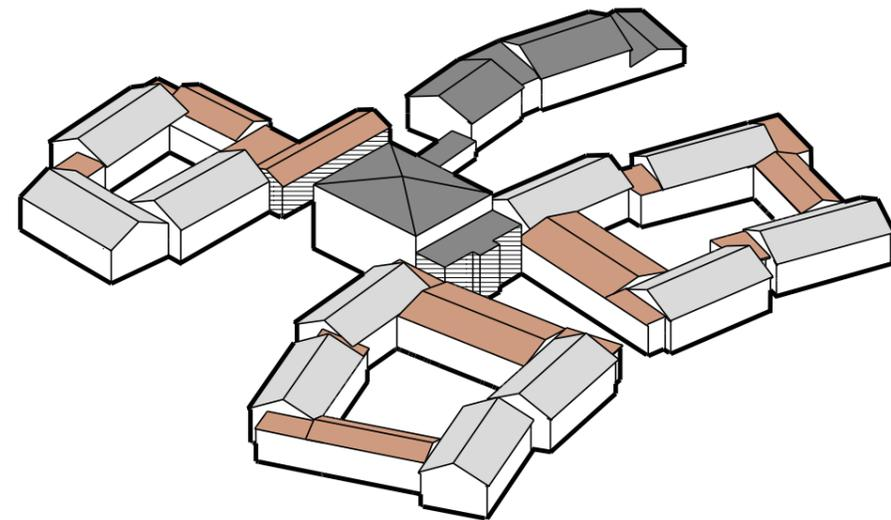

4. Playing with the roofs to get a village feeling

- Residential
- Common spaces
- Public
- Communication

# Level guide & connections

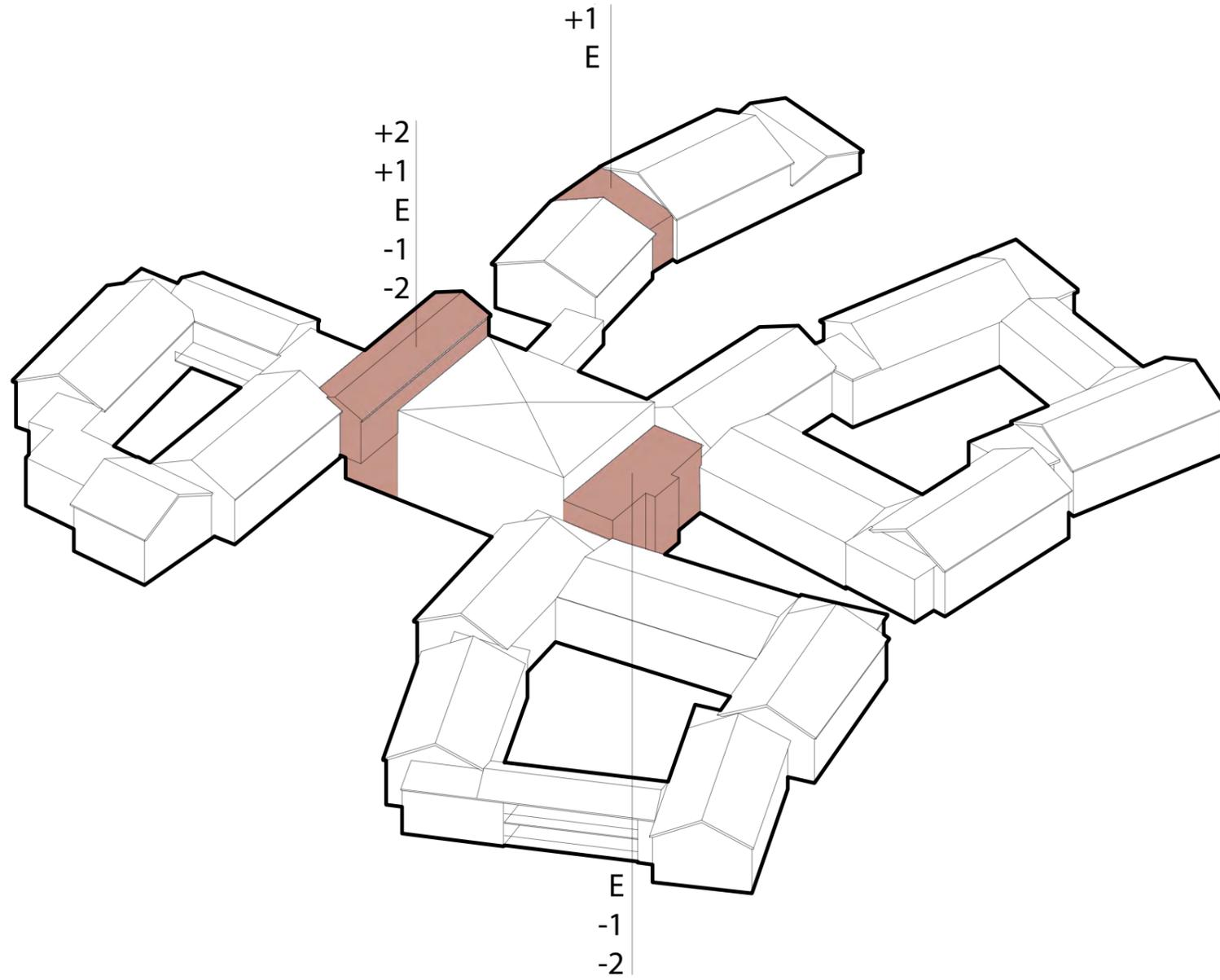

Vertical connections

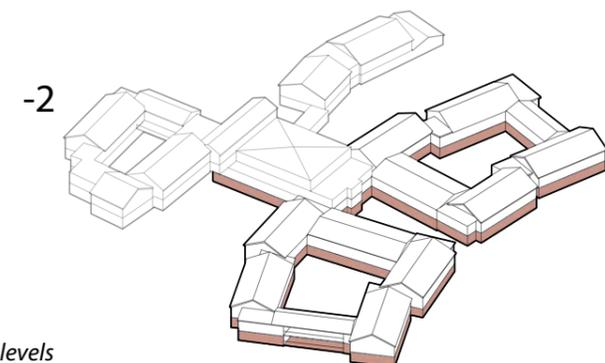
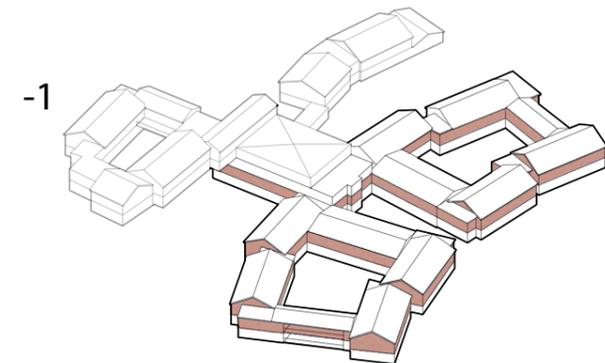
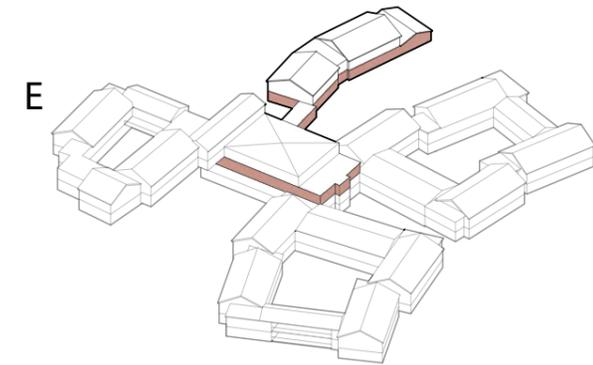
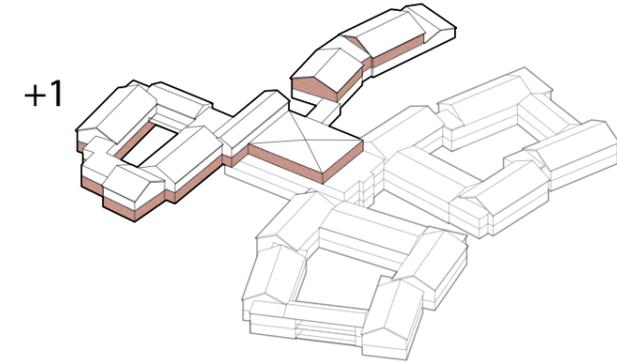
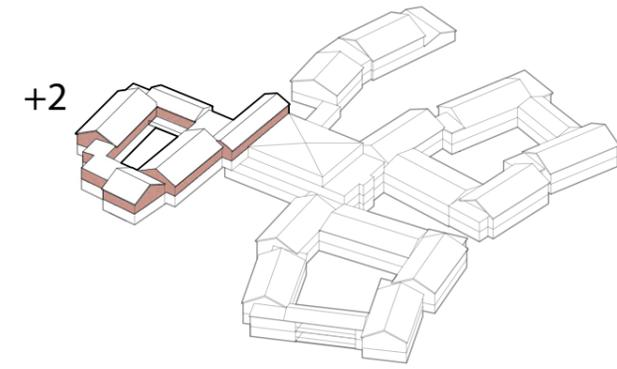

Different levels

# == Axonometric view with site

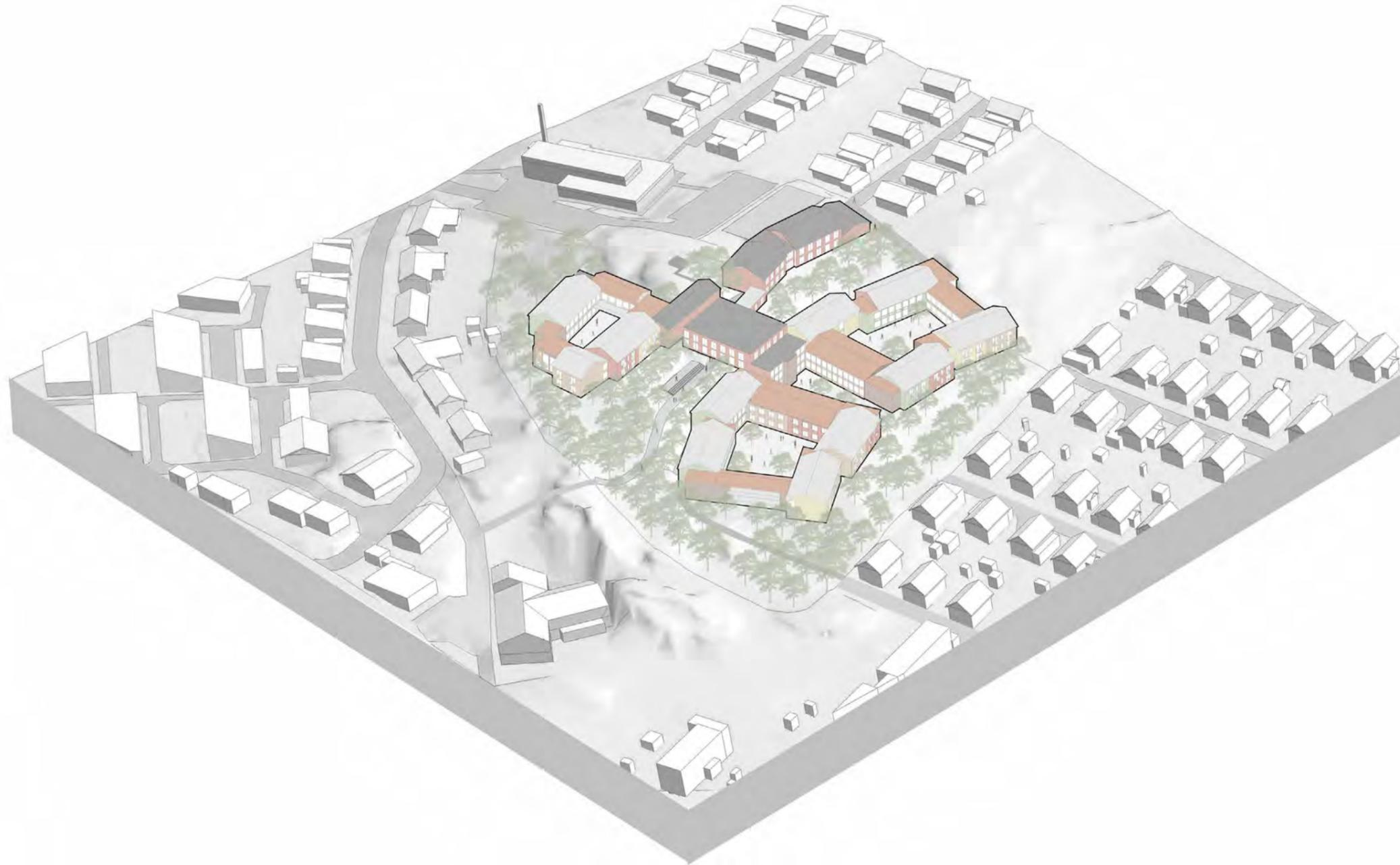

## PROJECT IN NUMBERS

---

Area of site: 22641 sqm

Gross total area built: 13400 sqm

Area dedicated to residents: 9800 sqm

Area dedicated to public functions: 2223 sqm

Secured outdoor area : 2002 sqm

3 courtyards

10 units

84 apartments

# Entrance building

## FUNCTIONS & ORGANISATION

The entrance of the village is located on the northern west side, in the highest area of the site, close to the existing church.

On the entrance floor (floor E), we can find the reception area and on the left the restaurant of the village with the kitchen. On the right, we can reach the small café which has a view on the village. Right after the café, visitors can use the gallery to reach the public building which serves all of the units. The gallery is an indoor solution to connect the entrance building to the rest of the facility. Looking at art is a good way to stimulate patients by feelings, motor function, contact with beauty. Many positive aspects that justify adding a space dedicated to art in the project. Any kind of art could be exhibited, artists' work or artwork from the residents or the children from the neighbouring schools.

On the upper floor (floor E+1), administration and staff have their own offices and spaces with all they need. The staff has its own terrace on top of the gallery. The conference room sits on the landing, close to the entrance for easy access without any risk of disturbing people working.

## DELIVERIES

On the back side, from Mickelsmässogatan, is the access for trucks and deliveries to the kitchen. To deliver the food in the whole facility, the staff can use the corridor on the side which is specifically for deliveries and has easy access to the western staircase in the public building that can reach all of the different floors.

### FUNCTIONS

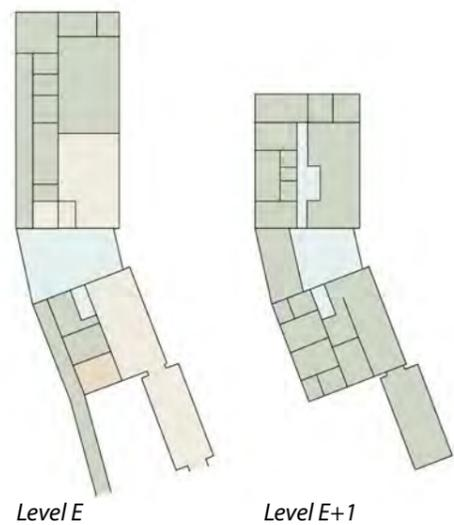

- Level E
- Level E+1
- Public
- Staff
- Communication
- Support areas

### FLOWS

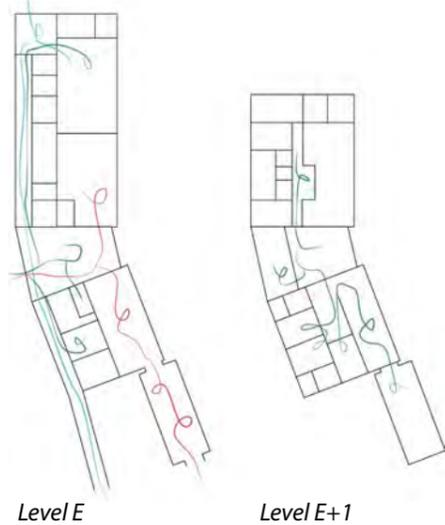

- Level E
- Level E+1
- Delivery
- Staff
- Visitors
- Residents

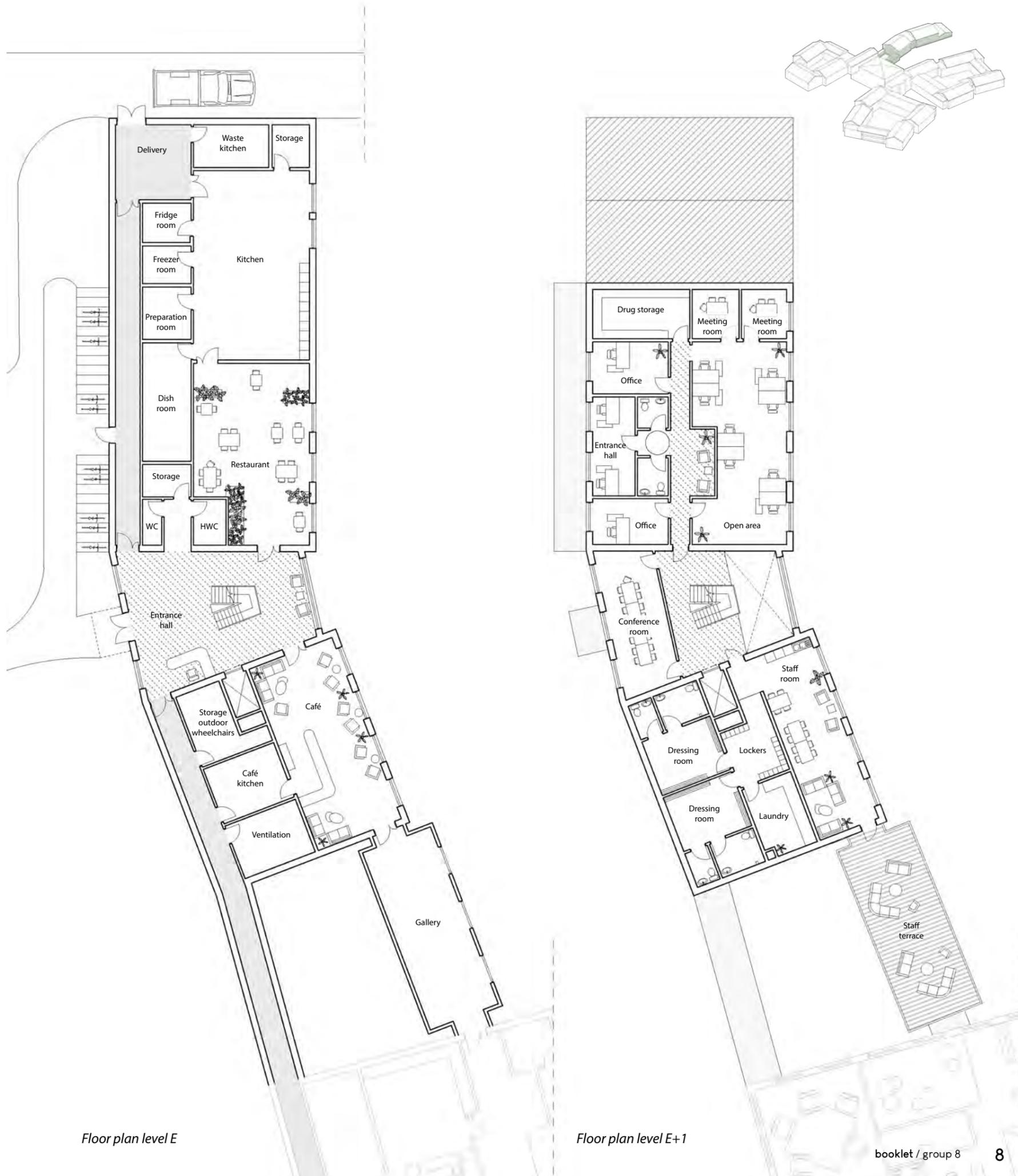
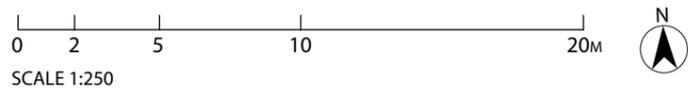

Floor plan level E

Floor plan level E+1



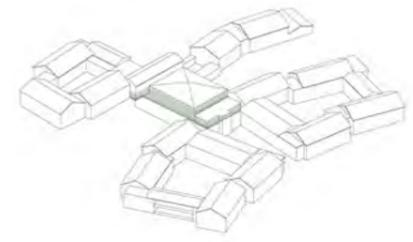

# Public building levels E & E+1

## PURPOSE

To strengthen the sense of community for the elderly, we wanted to have a public building that could be used by everyone in the neighbourhood. This public building is also the heart of the facility by disserving the two staircases leading to the units on the upper part and lower part of the site. Our concern about loneliness for elderly led us to design this building as a public space for the neighbourhood and residents, but also as a hub to facilitate navigation and flows in the facility. The nearby preschools can easily reach the community building by the south entrance. By creating this access, we hope for elderly to have the possibility to be surrounded by different people from different generations. The social aspect represents an important part in the feeling of belonging.

## FUNCTIONS & ORGANISATION

This building connects to the entrance building on the level E which we consider as neutral floor 0. On this floor, there is a lot of public functions for the residents and the neighbourhood such as the grocery store, the gym / motion room with access to the sauna, hairdresser, spa room, and beauty salon. The flexiroom is dedicated to medical use for appointments.

On the upper floor E+1, which benefits of a great location on site with good light exposure, there is a library which is accessible for everyone, and a room for manual activities. Here, children and elderly can share stories, activities can be organised. A room is also available to study, for high-school students from the neighbourhood for instance.

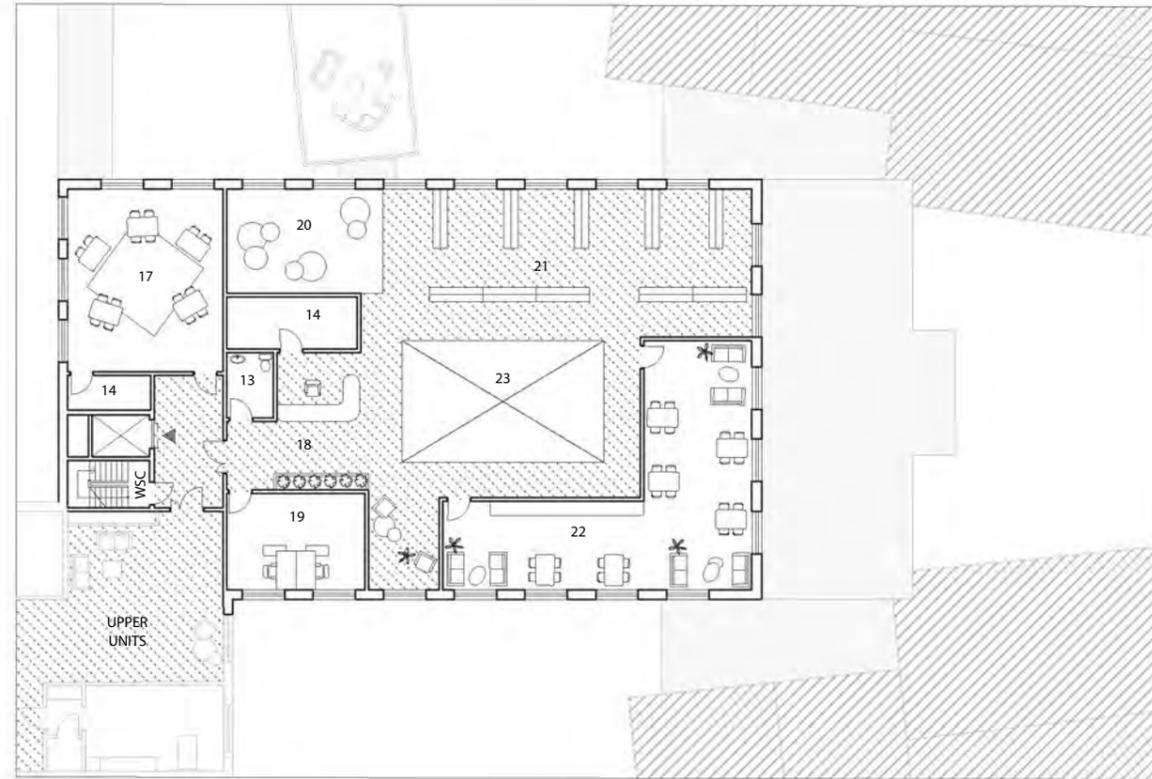

Floor plan level E+1 1:400

### FUNCTIONS

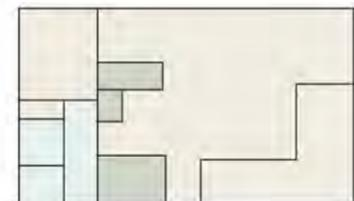

Level E+1

### FLOWS

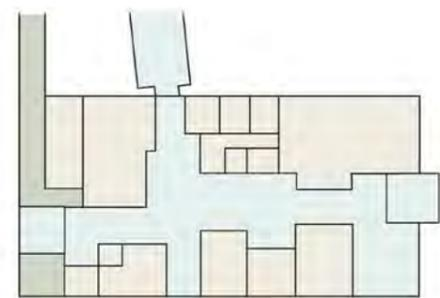
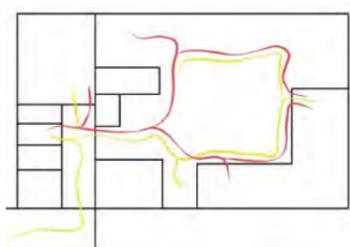

Entrance level

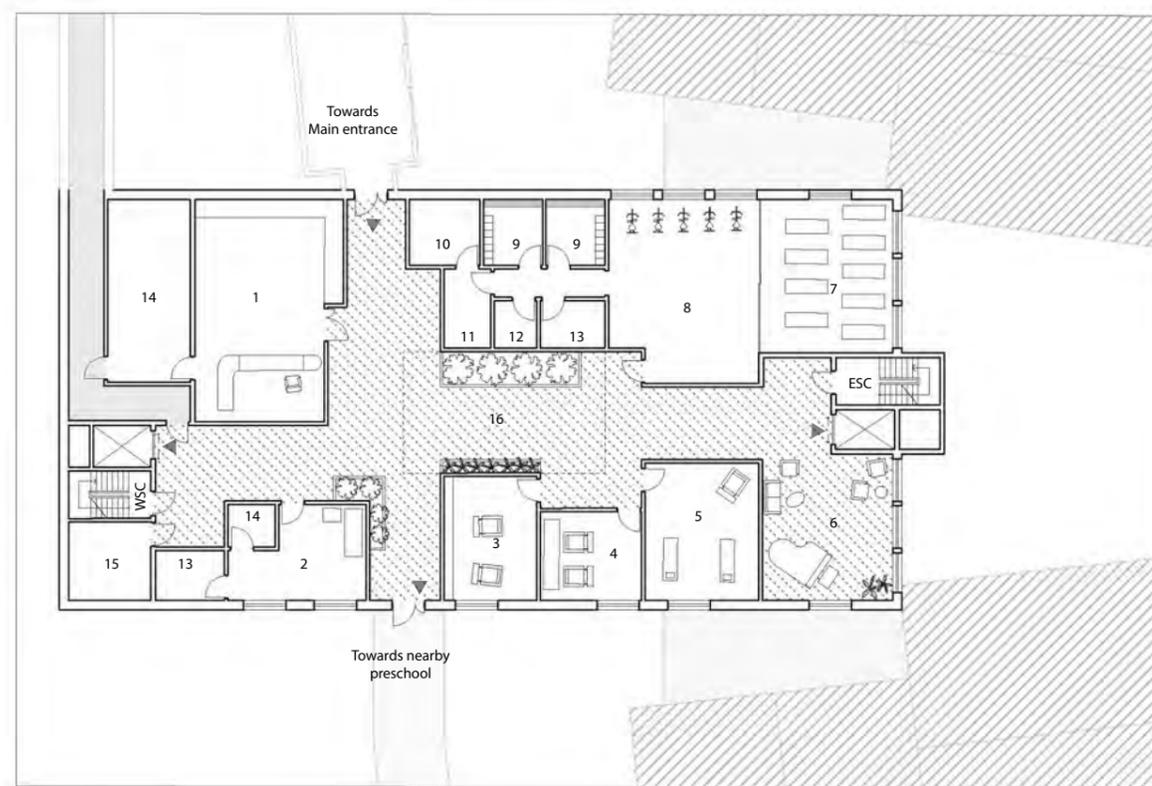
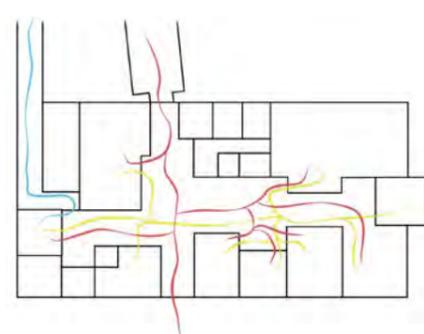

Floor plan 0 / Level E 1:400

- 1. Grocery store
- 2. Flexiroom / Medical room
- 3. Hairdresser
- 4. Beauty salon
- 5. Spa
- 6. Music hall
- 7. Yoga room
- 8. Gym
- 9. Dressing rooms
- 10. Sauna
- 11. Showers
- 12. WC
- 13. HWC
- 14. Storage
- 15. General storage
- 16. Opening on the upper floor
- 17. Manual activities
- 18. LIBRARY - reception
- 19. Office
- 20. Children area
- 21. Books area
- 22. Study and reading room
- 23. Void over the lower floor

WSC: Western staircase  
ESC: Eastern staircase

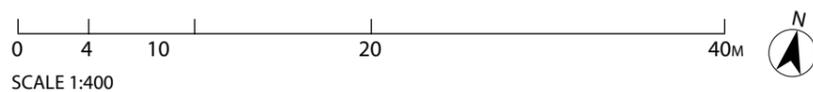

SCALE 1:400

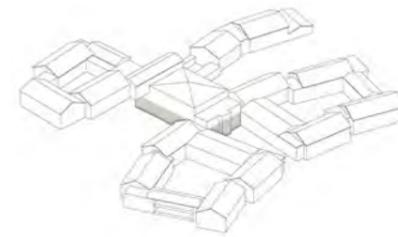

# Public building levels E-1 & E-2

## FUNCTIONS & ORGANISATION

On the lowest floors E-1 and E-2, we can find technical rooms and support areas since this part of the building is carved in the slope. On the lowest floor, we have the auditorium or cinema room which can host up to 110 people. This auditorium can be used for performances by the children or for the children and the elderly. It can be a way to reunite people around art, dance, music... for different kind of events. For a more usual use, movies can also be projected for the residents or the neighbourhood.

The western staircase (WSC) reaches all of the five floors in the facility. This access facilitates the flows for delivery in the whole facility. As a visitor, the eastern staircase (ESC) leads you to the auditorium on floor E-2. This floor has also access to the outdoor, with a great view on the villas in the east part.

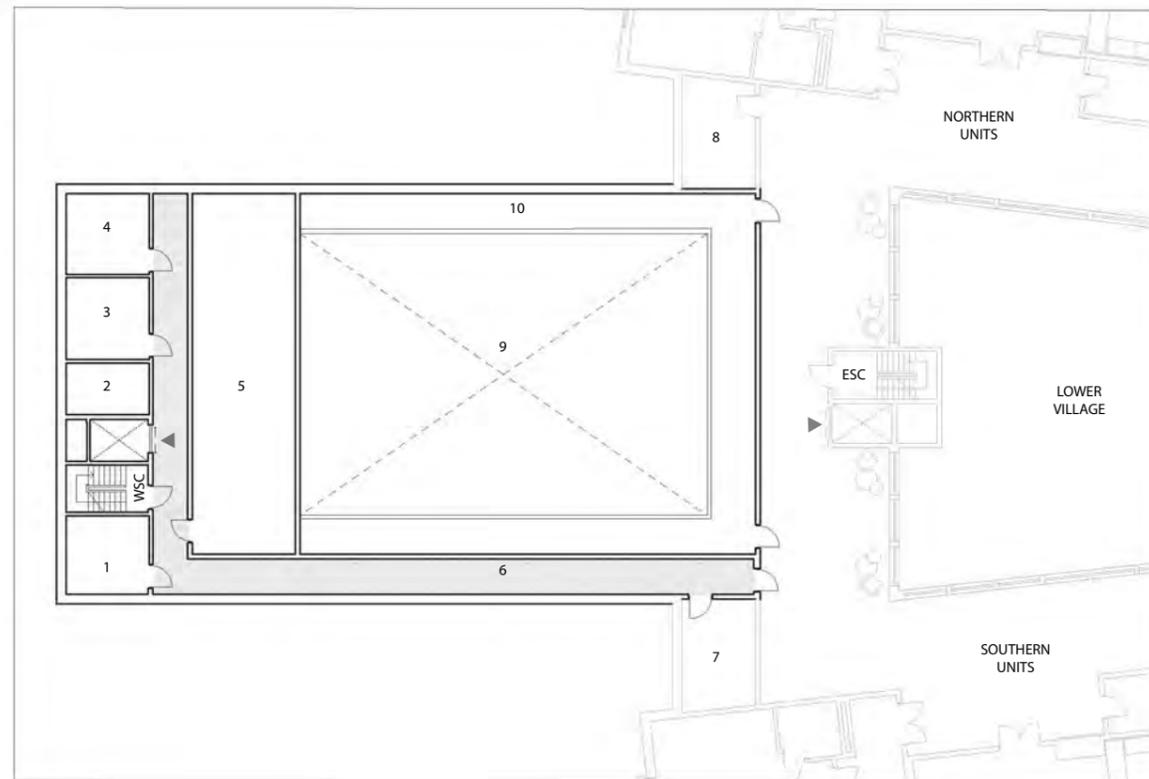

Floor plan level E-1 1:400

### FUNCTIONS

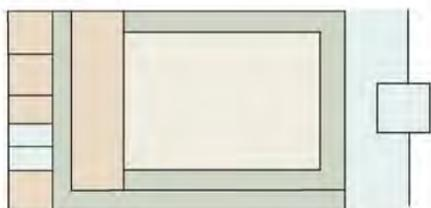

Level E-1

### FLOWS

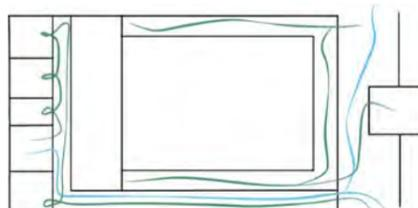

Level E-2

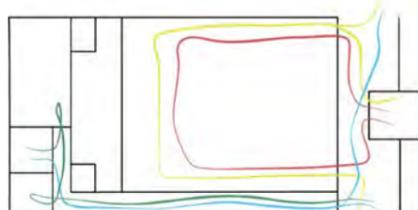

- Public
- Staff
- Communication
- Support areas

- Delivery
- Visitors
- Staff
- Residents

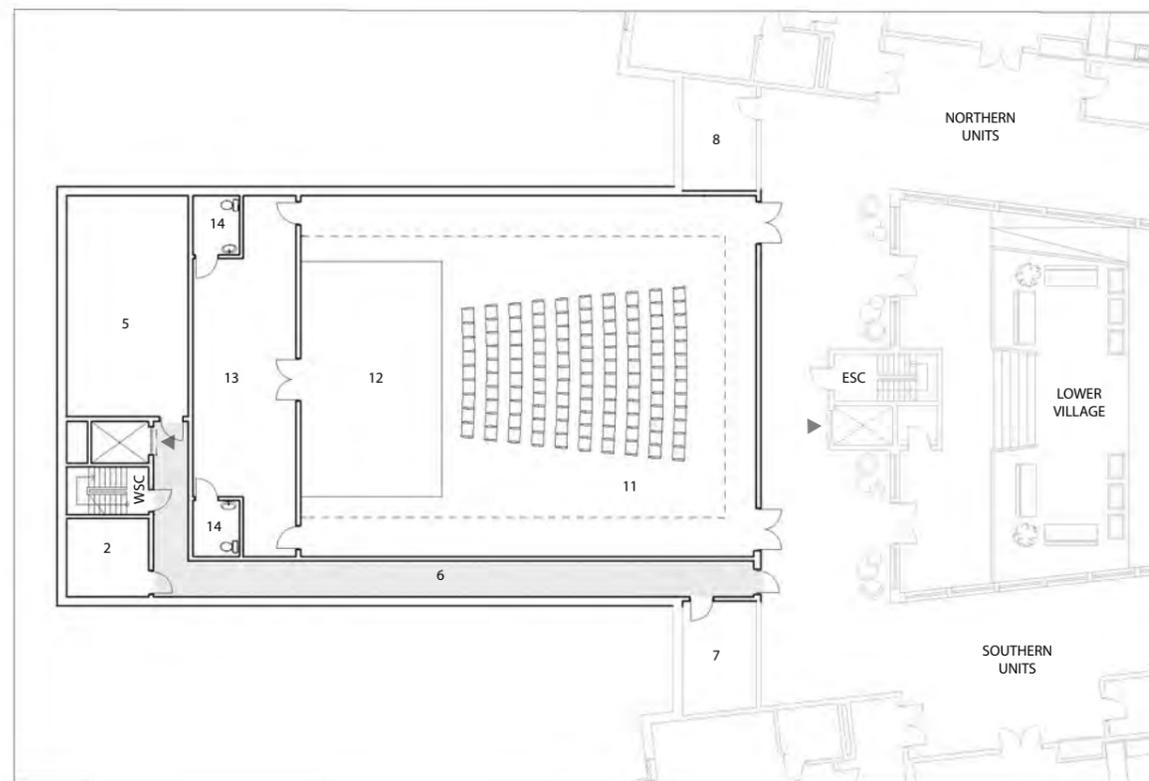

Floor plan level E-2 1:400

1. Cleaning central
2. Storage
3. District heating
4. Sprinkler room
5. Ventilation
6. Deliveries access
7. Waste Lower Village - Southern units
8. Waste Lower Village - Northern units
9. Void over the auditorium
10. Technical pathways
11. Auditorium
12. Stage
13. Preparation and dressing room
14. HWC

WSC: Western staircase  
ESC: Eastern staircase

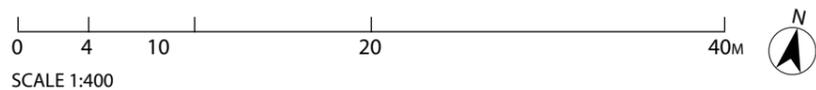

SCALE 1:400

# Courtyard



# Lower village - Southern units

## ORGANISATION

The lower village sits on the eastern part which naturally is the lowest part of the site. It is split in two volumes, the northern one and the southern one which are quite similar, they both have two floors. Each volume contains four units: two units of 8 residents per floor.

To reach the lower village, when you come from the entrance, you pass through the gallery and the public building to reach the eastern staircase, then you can choose to go on level E-1 or E-2.

Here we can see the lowest floor of the southern building (floor E-2). These two units have direct access to the courtyard. The two units are facing each other in order to share the circular movement which is good for wandering. They can also be secured and split in case of disease. The common spaces and corridors are facing the inner courtyard to encourage the residents to go outside. Two units share a big covered balcony to benefit from a nice space in-between outdoor and indoor.

The courtyard is the perfect place to have a small walk outside, gardening with other residents, playing boule, having a barbecue or reading on a bench when it is good weather.

The staff has one room close to the units and support areas for ventilation can be found on the upper floor.

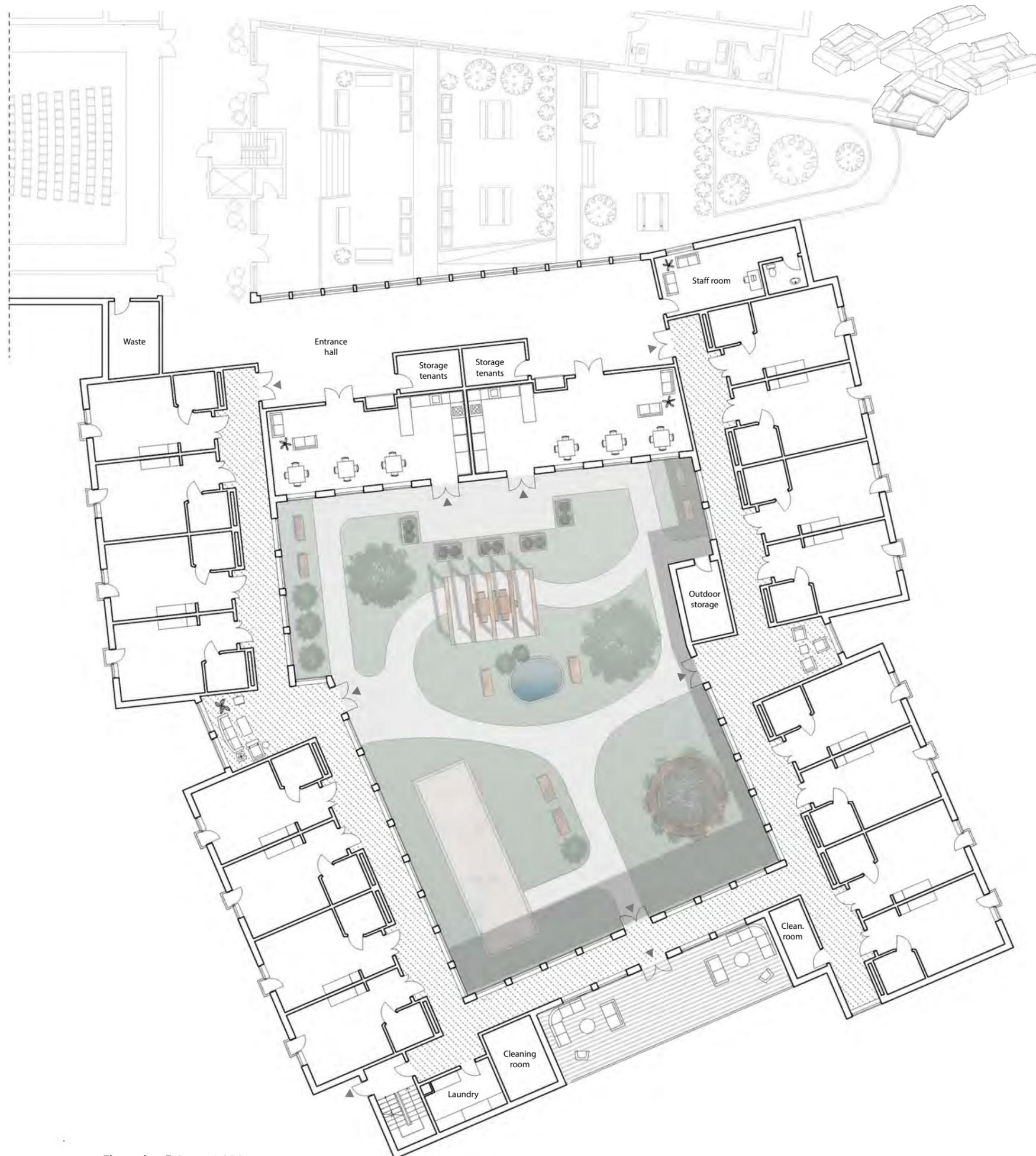

## FUNCTIONS

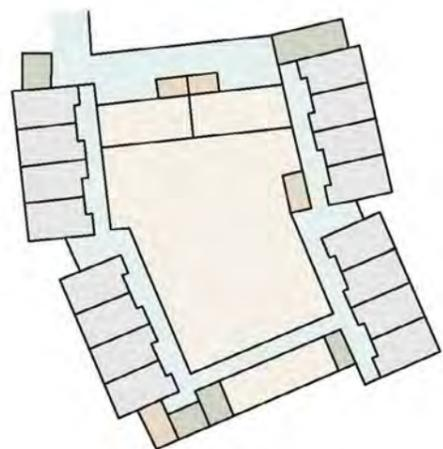

## FLOWS

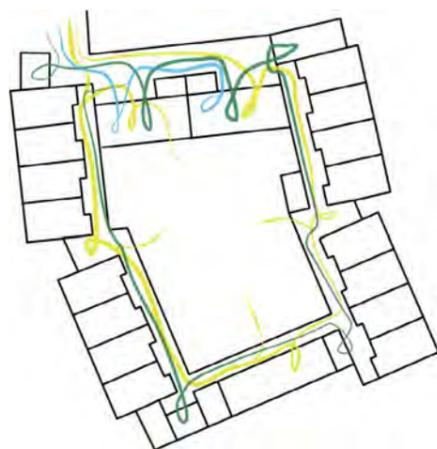

- Apartments
- Common spaces
- Communication
- Staff
- Support areas

- Delivery
- Staff
- Residents

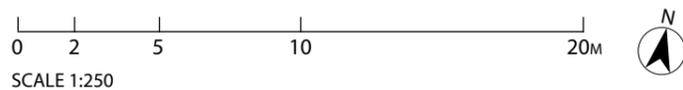

Floor plan E-2 1:250

# Courtyard



# Upper village

## ORGANISATION

The upper village consists approximately of the same layout than the smaller units but it has only one volume, but still with two floors.

To reach the upper village from the entrance, you go through the gallery and the public building and you take the western staircase (WSC). Then you can choose between the floors E+1 or E+2.

Here we can see the lowest floor of the upper village (floor E+1). This building consists of only one unit of 10 residents per floor. They can enjoy the big common spaces and the terrace facing the courtyard. As the other units, small nooks with couches create dynamism and break monotony in the corridors. The residents are free to use the courtyard according to their wishes and they also have access to a winter garden.

The staff also has its own room and close access to the main communication hub.

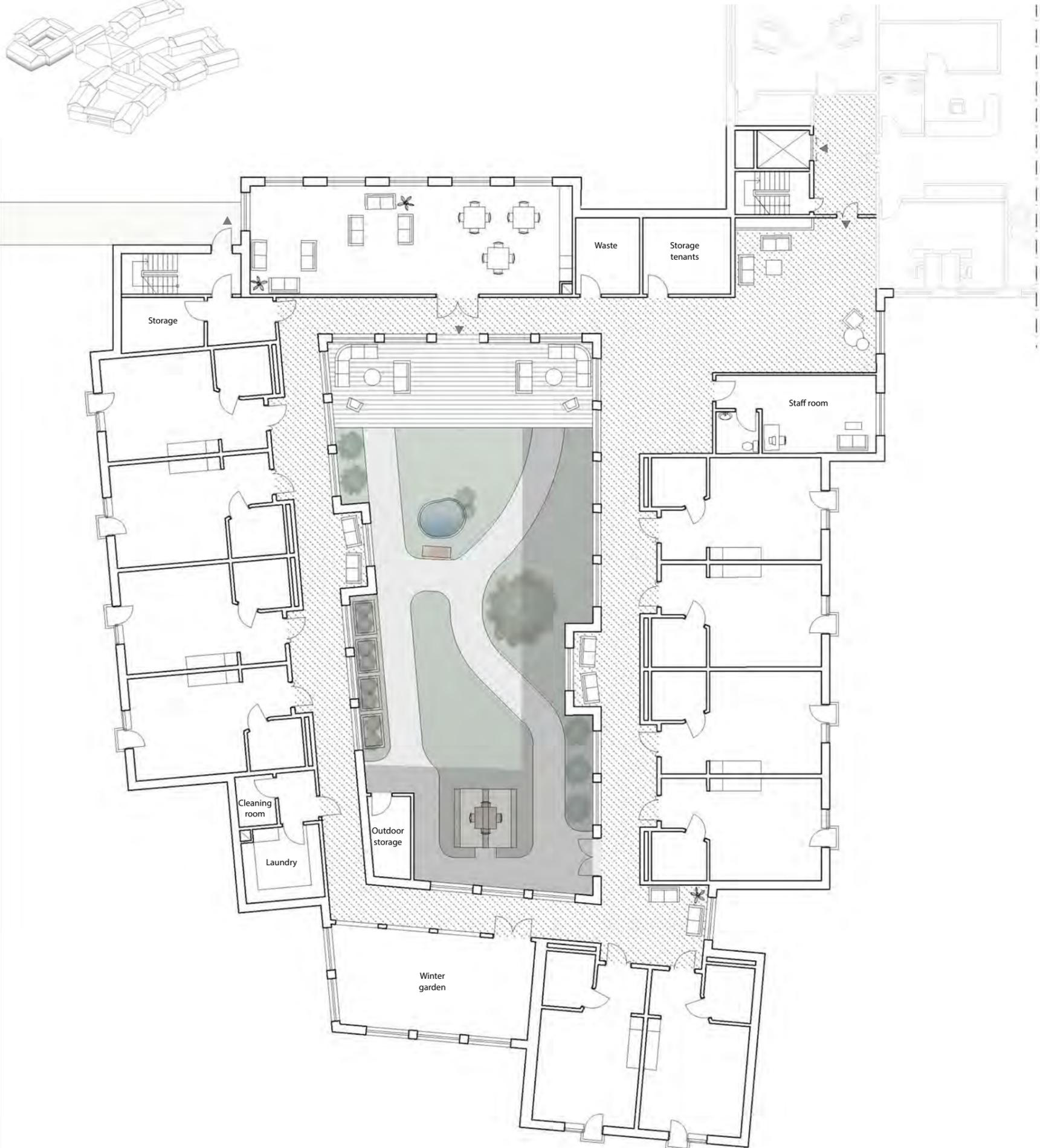
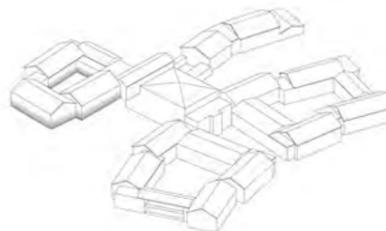

## FUNCTIONS

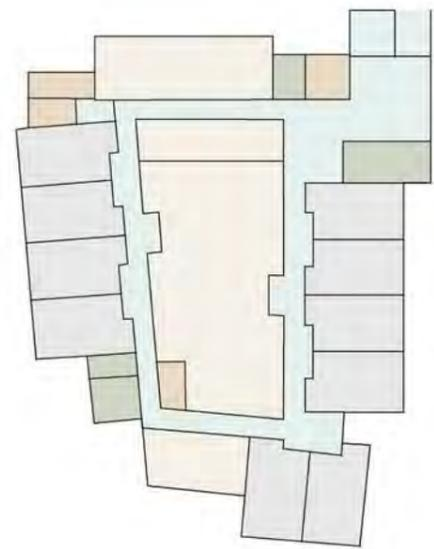

## FLows

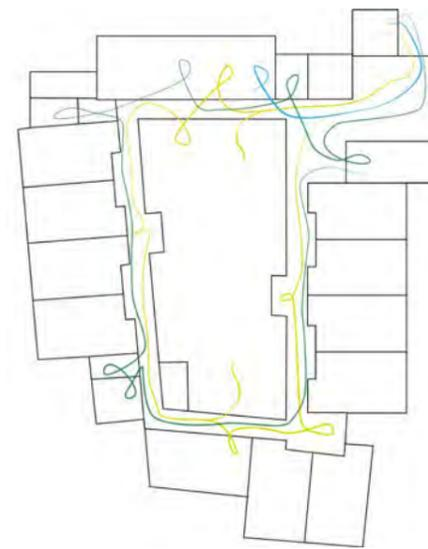

- Apartments
- Common spaces
- Communication
- Staff
- Support areas

- Delivery
- Residents
- Staff

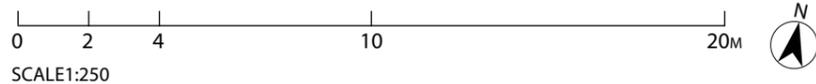

Floor plan E+1 1:200

Corridor



# Sections

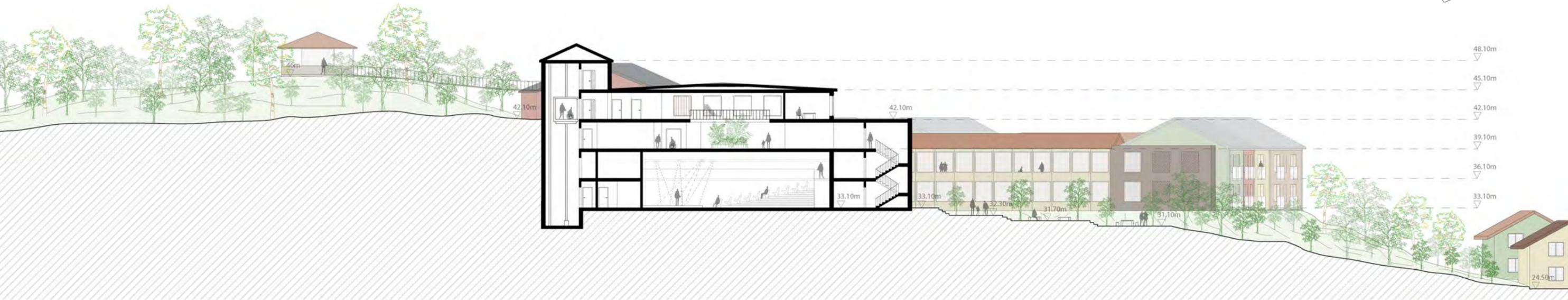

Section A-A' West-East through the community building



Section B-B' West-East through the units and the courtyards

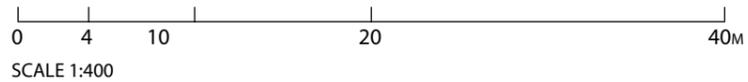



# Facades

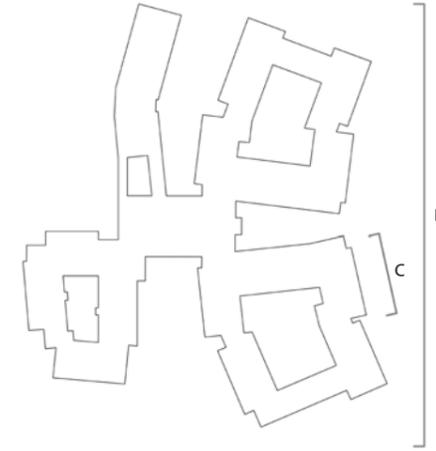

Facade C - Residential part (block of four apartments)

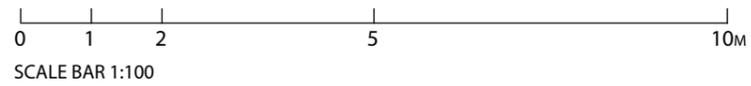

East elevation D

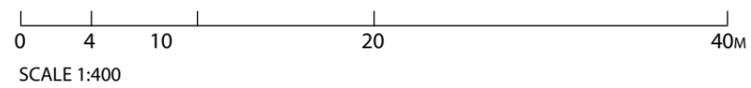

# Apartment

## ORGANISATION

The village counts 84 single apartments of 35m<sup>2</sup> composed of a small entrance with wardrobe and storage for wheelchair, a kichenette, the living and bed area and the accessible bathroom. The apartments work in blocks of four apartments and each time, two apartments that are mirrored share the shafts.

The recess for the entrance door creates comfortable private entrances. By having, the door of the bathroom on the side, the movement is simplified and less risk of injuries when elderly wake up during the night. The simple layout of the room makes it efficient and offers flexibility in furnishing. It has been proved that nature takes part of a better healing process by being in close proximity to great environments. So to optimize the connection with nature, the residents have a large window with a french balcony from where they can look at the neighbourhood.

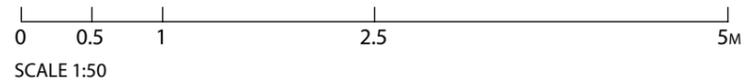
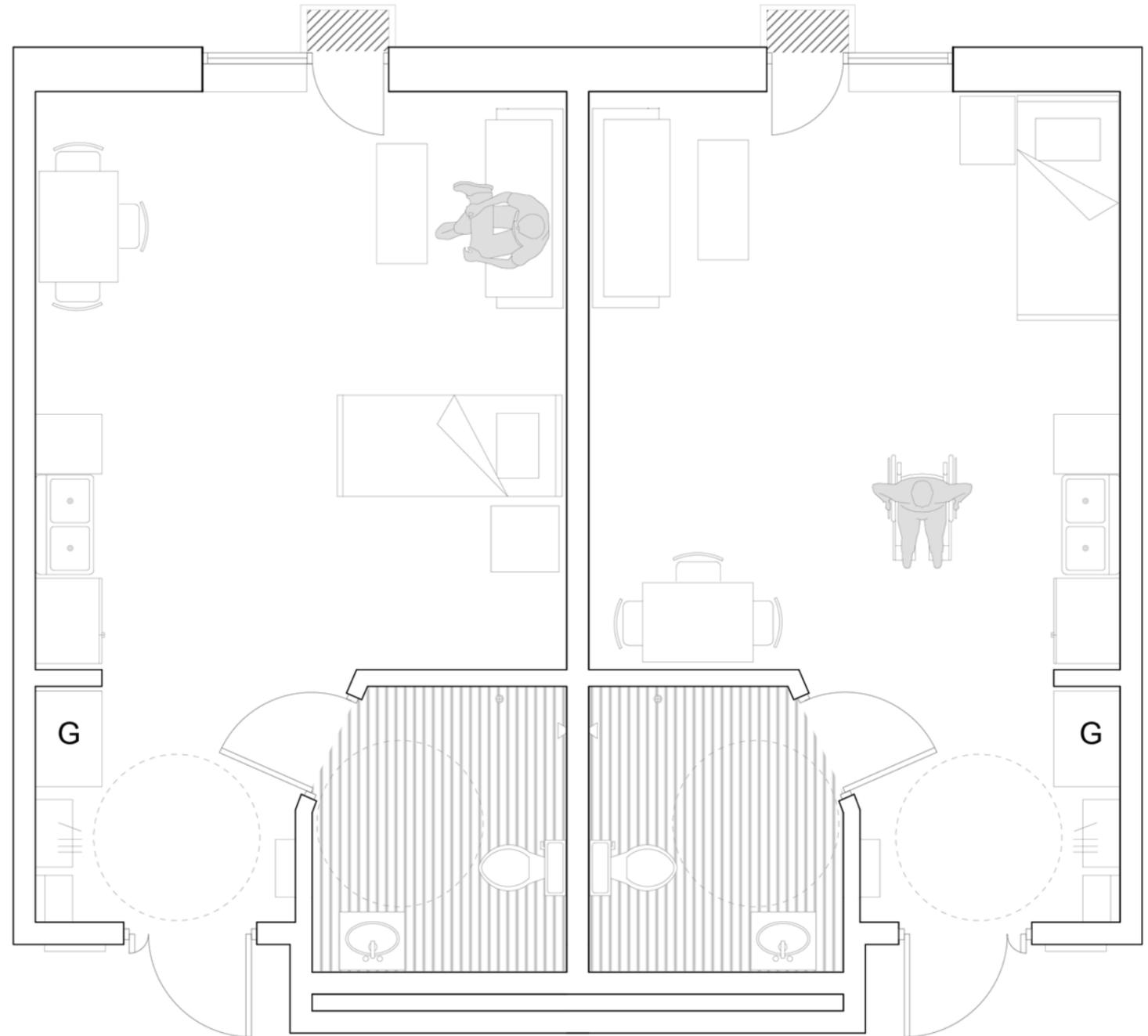

Apartment plan 1:50

# Apartment



# THANK YOU!

*GROUP 8 - Emma Law-Bo-Kang, Linus Sjöström Fransson, Afsaneh Tayebi*

